

OPERATION & MAINTENANCE INSTRUCTIONS SHARPE MIXERS TOP ENTRY WITH STUFFING GLAND

TABLE OF CONTENTS

SECTION A	MIXER DATA SHEET & DRAWINGS	A-1
SECTION B	INITIAL INSPECTION, RECEIVING AND STORAGE	B-1
	MOUNTING THE DRIVE	B-2
	INSTALLING THE MIXER SHAFT	B-2
	INSTALLING THE MIXER IMPELLER	B-3
	INSTALLING THE STEADY BEARING (<i>optional equipment</i>)	B-3
	VAPOR SEAL MAINTENANCE (<i>optional equipment</i>)	B-4
	STUFFING GLAND PREPARATION & LUBRICATION	B-4
	MOTOR CONNECTIONS & LUBRICATION	B-6
	START UP & OPERATION	B-8
	TROUBLE SHOOTING GUIDE	B-9
	RECOMMENDED SPARE PARTS	B-12
	WARRANTY	B-12
SECTION C	SPEED REDUCER LUBRICATION & MAINTENANCE	C-1
	SPEED REDUCER PARTS	C-3
SECTION D	MISCELLANEOUS DETAILS & INSTRUCTIONS (<i>when required</i>)	

SECTION B

INITIAL INSPECTION, RECEIVING AND STORAGE

B1.1 Immediately upon receipt of the equipment check the crating and contents for any damage that may have occurred in transit. Report any damage immediately to the carrier and to *Sharpe Mixers*. Check against the packing slip to be sure that all parts were received. Report missing items to the carrier and *Sharpe Mixers*.

B1.2 The drive unit, impellers and the mixer shaft are normally packed in a separate containers. If space allows, keep shipping containers for possible future use.

B1.4 **Storage:** Storage is when a) mixer has been delivered to the job site and is awaiting installation, b) mixer has been installed, but regular operation is delayed, c) there are long idle periods between operating cycles, d) plant/department operation is shut down. Store mixer in a clean, dry location, with circulating air, free from wide variations in temperature. Electric motors are easily damaged by moisture. Store the entire unit off the floor, covered with plastic, and use desiccants to reduce moisture buildup. Do not seal the plastic cover as this traps moisture. If the motor shows signs of moisture absorption before start-up, dry the motor out by applying 10% voltage on two leads (if in doubt, measure resistance in windings, one to three megohms is normal). This will give approximately 50% rated current. There are also sprays available to help

dry out motors. Relubricate motor before start-up when in storage six months or more. Storage of mixers over six months must have gear reducers filled completely with storage oil. Do not install vent plug when in storage. Spray oil on exposed lip seals and unpainted carbon steel parts. Rotate motor and gearbox shafts periodically. When returning to service, drain storage oil, clean with mineral spirits, and replace with correct lubricant (see Section C).

MOUNTING THE DRIVE

B2.1 Mounting structure must be stable and strong enough to handle torque, bending moment, and weight specified on assembly drawing. The structure must not flex or vibrate when the mixer is in operation. If mounting to an unstable support, mixer loads may cause damage to the equipment, tank, or other hazards.

CAUTION: DO NOT LIFT MIXER BY THE SHAFT. DO NOT LIFT THE MIXER USING THE LIFTING LUG OF THE MOTOR ALONE. USE SLINGS TIGHTENED AROUND THE MIXER DRIVE.

B2.2 Mixer drives with mounting plates may need to be shimmed for shaft to be vertically aligned and then bolted securely to the mounting structure. Flange mounts must have gaskets between flanges before bolting securely for proper sealing. When a remote seal is used, seal must be concentric and

perpendicular to mixer shaft. Using lock washers or double nutting the mounting bolts is recommended to prevent bolts from loosening by equipment vibration.

B2.3 When foot mounted motors are supplied, readjust the motor after installation for proper alignment of the flexible coupling (see Paragraph B10.8).

INSTALLING THE MIXER SHAFT

WARNING: Always lockout power before installing or removing mixer shaft.

B3.1 If the mixer shaft is a two-piece design, the upper shaft is normally installed at the factory. If not, mixers with shaft seals must have the mixer shaft raised through the seal area carefully. Some seals will have parts (shipped separately from the drive) which need to be installed in sequence while installing the mixer shaft. Refer to the detail drawings in front of the manual. Note the type of couple to the drive on the assembly drawings and install shaft per the following means:

B3.2 **Hollow bore drive:** Remove cover over hollow bore on drive (when supplied). Remove hold washer and protective wrap on top of mixer shaft. Clean machined section of shaft of any rust/grit and lubricate lightly with NEVER-SEEZ® compound. Raise mixer shaft from below and through seal. Install the shaft into the drive (see Figure B3.1). Be sure key is in place. Do not hammer parts in place. If keys do not fit, grind to size. Before bolting hold washer in place, add NEVER-SEEZ® compound (supplied) to the top of shaft. The top hold bolt must be installed dry, and threaded into top of shaft a distance equal to at least one bolt diameter. Tighten the hold washer bolt to the torque ratings listed in table B3.1 using a torque wrench / socket combination for best results. Reinstall the hollow bore cover (when supplied).

B3.3 **Split coupling drive:** Remove split coupling from drive shaft. Raise mixer shaft from below and through seal (see Paragraph B3.1). Bolt hold washer to top of mixer shaft (if not already done). Install keys on both shafts. Do not hammer parts in place. If keys do not fit, grind to size. Make sure all parts are clean, and assemble split coupling halves onto shafts (see Figure B3.2). The split coupling has one end marked "drive" on each half. This end must face the gearbox for proper alignment. Replace split coupling. Be sure gap is even on both sides of coupling. Tighten split coupling bolts to the torque ratings listed in Table B3.1. Tighten from the center out, in an opposite/diagonal sequence. It is critical that shaft alignment be checked closely after installation with split couplings. Improper toquing, an oversize key or eccentric washers can cause misalignment and problems during operation. See B3.5.

B3.4 **Flange coupling (optional):** Clean mating surfaces of any nicks or grit which may cause misalignment. Raise mixer shaft to mate to flange coupling. Bolt flanges securely together (see Figure B3.3). Be sure flanges mount flush.

B3.5 Remove motor fan guard and turn fan by hand to check that mixer shaft turns freely and alignment is true. Repeat once impellers are installed.

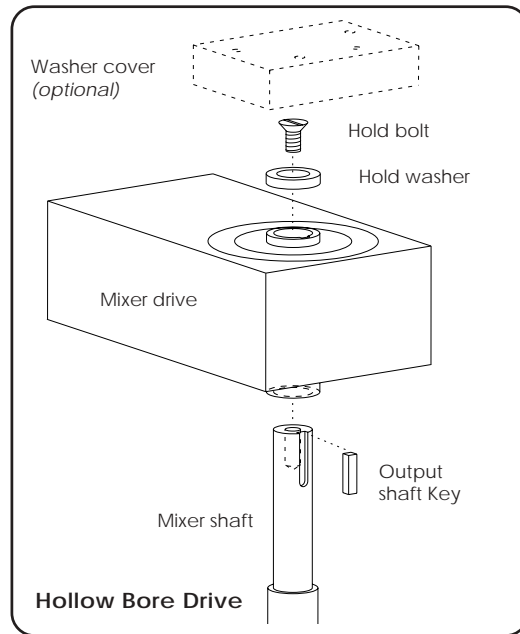

FIGURE B3.1

Table B3.1

Bolt Torque Ratings

5/16" bolt @ 10 ft.-lbs.	3/8" bolt @ 25 ft.-lbs.
7/16" bolt @ 35 ft.-lbs.	1/2" bolt @ 45 ft.-lbs.
5/8" bolt @ 75 ft.-lbs.	3/4" bolt @ 130 ft.-lbs.
7/8" bolt @ 200 ft.-lbs.	

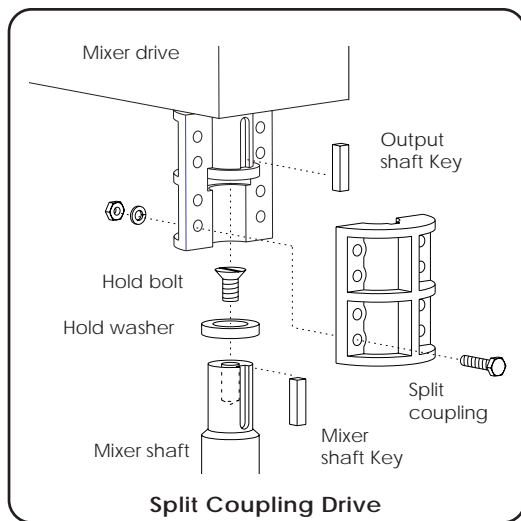

FIGURE B3.2

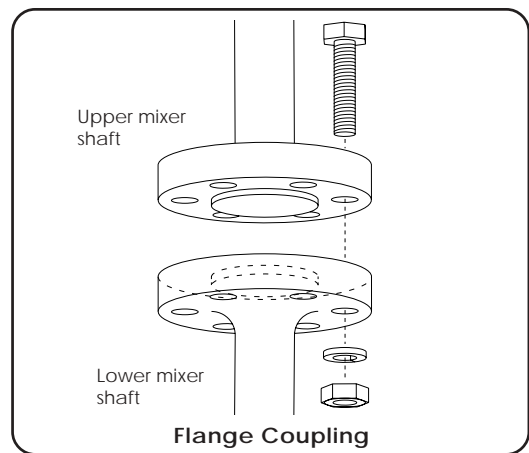

FIGURE B3.3

INSTALLING THE MIXER IMPELLER

WARNING: Always lockout power before installing or removing impeller.

B4.1 Refer to mixer assembly and impeller detail drawings for proper impeller rotation, positioning, and placement.

B4.2 1-Piece Impellers: Slide the impeller on the shaft facing the correct way (according to the assembly drawings). Impellers without keys setscrew directly onto shaft. When divots are in the shaft, bolt the setscrew directly into divot. For impellers with keys, position the key with pin (if present) below the impeller. Tighten the setscrew securely.

B4.3 Split Hub Impellers: Clamp split hub impellers to shaft. If impellers were shipped with shims, discard prior to assembly, do not use to assemble on mixer shaft. Be sure to maintain 1/4"

gap between hubs (except 2-blade split which the gap will be shown on the impeller detail drawing) to insure correct blade alignment and vibration free operation. When torque pins are present on mixer shaft, clamp so the socket in the hub fits over the shaft pin. Tighten split hub impeller bolts to the following torque ratings:

Bolt Torque Ratings (split impeller bolts only)

1/2" bolt @ 29 ft.-lbs.	5/8" bolt @ 54 ft.-lbs.
3/4" bolt @ 96 ft.-lbs.	7/8" bolt @ 150 ft.-lbs.

Table B4.1

B4.4 Other types of impellers are: Bolted blades in which blades must be securely bolted to the tabs welded to the shaft; Welded blades in which require no special installation work.

INSTALLING THE STEADY BEARING

(optional equipment)

WARNING: Always lockout power before installing or servicing the steady bearing. Never run mixer without the steady bearing installed.

B5.1 This section is for mixers which include an optional steady bearing to accommodate longer than standard mixer shafts. A steady bearing must be installed only after the drive assembly and lower mixer shaft have been assembled and firmly bolted in place. DO NOT predetermine the bearing location from tank and mixer outline dimension drawings. The vertical center line of the steady bearing must

coincide with the shaft's natural axis of rotation to minimize bearing preload (see Figure B5.1). This axis may not necessarily be at the center of the tank. The mixer shaft must be hand rotated (using input shaft coupling or motor fan) with a fixture attached to the shaft to mark a line on the tank bottom. The center of this inscribed area will be the location for the center of the steady bearing.

B5.2 The steady bearing must be securely installed with its vertical centerline aligned with the axis of rotation of the shaft, as established in Paragraph B4.1. The amount of lateral movement re-

quired to bring the shaft into proper alignment with the final steady bearing location will vary depending upon the shaft length and diameter.

B5.3 The shaft/wear sleeve must be fully engaged with the bearing.

B5.4 The steady bearing and wear sleeve are wearing parts and should be checked periodically. It is recommended that a spare bearing and wear sleeve be kept in stock at all times.

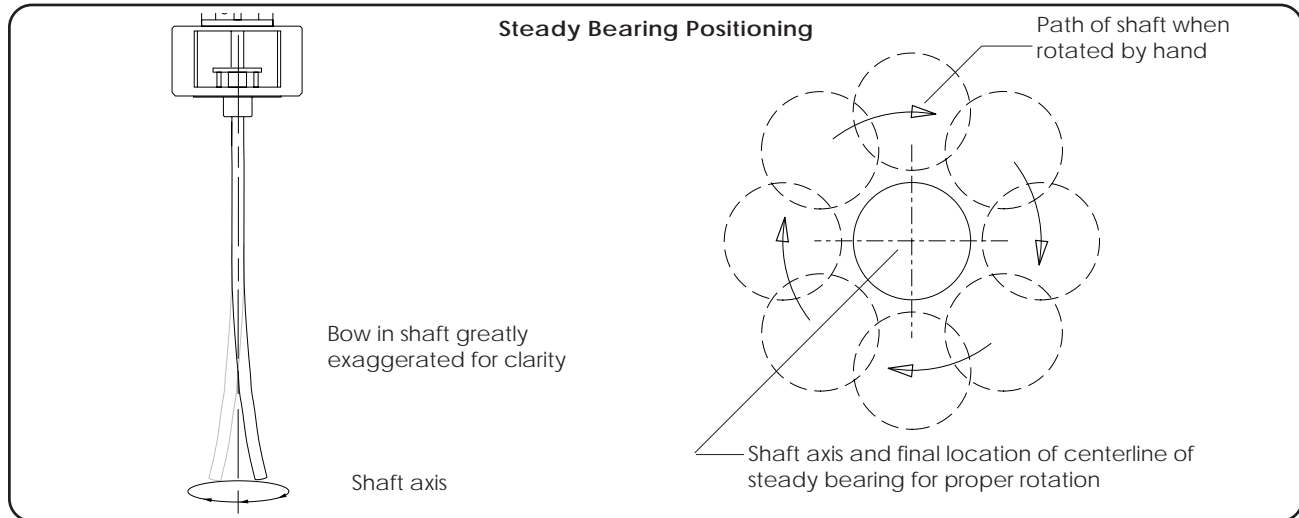

FIGURE B5.1

VAPOR SEAL MAINTENANCE

(optional equipment)

B6.1 Vapor seals will seal vapors from the product but will not hold pressure. No lubrication is required. Replace vapor seals periodically when wear is apparent. To replace, remove mixer shaft from gearbox. Remove gearbox from flange. Seals may now be removed and replaced.

B6.2 When oil is noticed leaking from the flange drain, gearbox seals have failed and mixer must be shut down and gearbox seals replaced immediately to avoid further gearbox damage.

STUFFING GLAND PREPARATION & LUBRICATION

B7.1 The purpose of packing is to control leakage, not prevent it. Packings must leak to perform properly, otherwise they will burn up. TFE packings are especially sensitive in this respect.

B7.2 **Low pressure packed gland:** Two rings packing is standard from the factory. This gland is designed for 15 psi of tank pressure. No lubrication is required.

B7.2.1 **Remote mounted seals:** (mounted separate from the drive) must be installed in sequence while installing the mixer shaft. Before tightening the seal mounting bolts, center the seal flange around the shaft. Remove the follower ring and packing and slide four (4) 0.030"/0.035" diameter shims between the flange face and the shaft (small paper clips may work in lieu of shims), and tighten flange in place.

B7.3 **High pressure packed gland:** Seven rings with lantern ring is standard from the factory. This gland is designed for 150 psi of tank pressure. A zirc fitting is present on the seal housing and needs to be greased daily. A weight loaded lubricator or other self lubricating device is available from Sharpe Mixers to aid in seal lubrication.

B7.4.1 **DO NOT OVER TIGHTEN THE PACKING!** Gradually take up gland nuts 1/6 turn (1 flat in hex nuts) at a time. Watch temperature. **NEVER PERMIT HEAT TO DEVELOP - BACK OFF GLAND NUTS IF IT DOES.** For top entry mixers, temperature must be watched more carefully for overheating during start-up, since leakage cannot be measured.

B7.4.2 **PROVIDE FOR LUBRICATION,** particularly

when mixing non-lubricating liquids (high pressure glands only). For greasing, a zinc fitting is standard from the factory (see Paragraph B7.3 for lubrication instructions). For flushing, remove the 1/8" N.P.T. zinc fitting and replace with flushing lines (not included). Whenever flushing through a seal, a clean liquid having lubricating properties must be used.

B7.5 REPACKING THE GLAND: Packing tools: Special flexible corkscrew tools specifically designed for packing make seal servicing an easy task (see Figure 7.1). Various size tools are available from Sharpe Mixers.

B7.6 After power has been disconnected and tank depressurized, remove the old rings. If a lantern ring is present, there are (4) slots cut into the top outside edge. This helps the packing tools "grab" the lantern ring for removal. Use caution when removing old rings. Do not score shaft. Before installing the new rings, be sure that the new packing is of the proper type and size for your application (see Data Sheet in front of manual).

B7.7 If you purchase your packing rings from other than Sharpe Mixers, chances are you will have to cut the rings yourself. To do this, wind the packing around a mandrel of the same diameter as the mixer shaft for the desired number of rings (see Figure B7.2). Cut rings by making a straight cut along the mandrel, slip them off without opening the rings. This is especially important for metallic types. Do not open with a hinge-like action (see Figure B7.3).

B7.8 Check condition of stuffing box and the shaft in the seal area. If either are rough or scored, it needs to be reworked or replaced. Without repairing the damaged areas, gland take-up will result in distortion of the rings and over compression of the packing on the mixer shaft. The packing will not seal properly and will burn out sooner, further damaging

the seal area. If wearing in the seal area is evident contact the factory for recommendations.

B7.9 Coat new rings with a lubricant to assist with installation and break-in (Do not use on food grade packings, liquid oxygen service, nitric acid, or any other non-compatible application). Check position of all gland parts against the applicable seal drawing. Replace all worn or damaged parts.

B7.10 Install rings over the shaft by twisting open as shown in Figure B7.3. This is especially important for metallic rings. NEVER open rings with hinge like action.

B7.11 Insert rings one at a time with joints staggered 90° apart (for 2-ring low pressure seals, stagger at 180°). Seat each ring individually, compressing in place with a tamping tool or by using a split hollow cylinder. Turn mixer shaft occasionally to assist seating. Unless each ring is properly seated, the gland follower will not be able to tighten the packing set, as it will leave the front rings (nearest the follower ring) too tight in the stuffing box. Bear in mind that, except for abrasives, 70% of the wear normally takes place on the two packing rings nearest the follower ring. Proper seating and lubrication spreads the wear out more evenly over the entire set of rings. Adjust follower finger tight only to begin. See Paragraph B7.1 for seal start-up procedures.

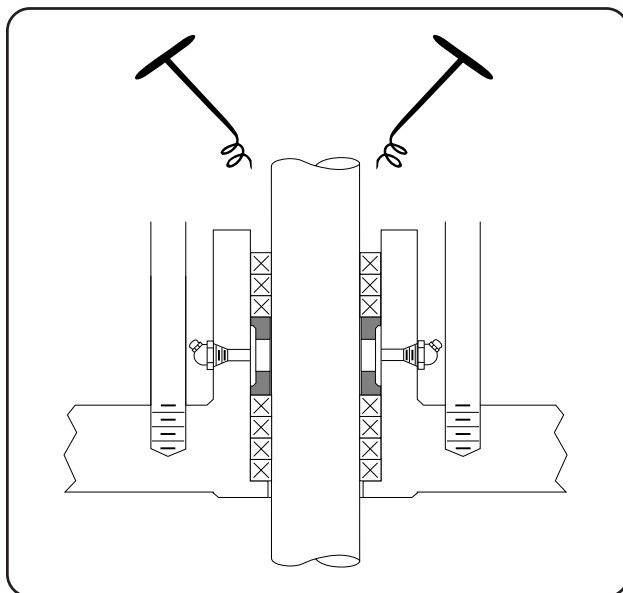

FIGURE B7.1

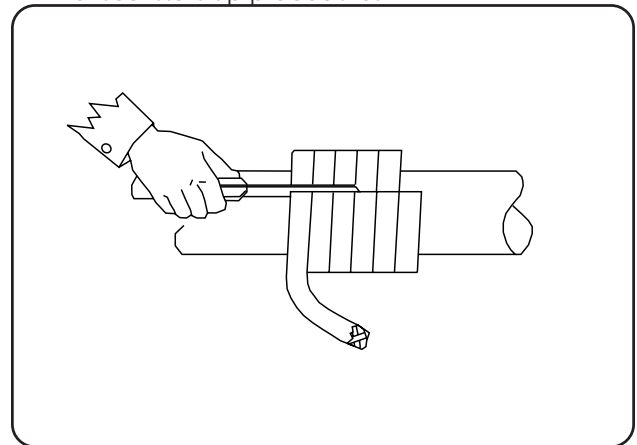

FIGURE B7.2

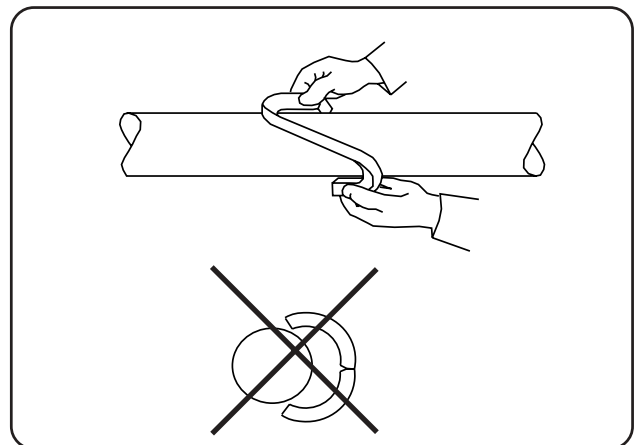

FIGURE B7.3

MOTOR CONNECTIONS & LUBRICATION

B8.1 WARNING: High voltage and rotating parts can cause serious or fatal injury. Electric machinery can be hazardous. Installation, operation, and maintenance of electric machinery should be performed by qualified personnel. Familiarity with NEMA safety standards, National Electrical Code and local building codes are required.

B8.2 Wiring: Starting and overload control devices must be matched to motor rating. Follow control manufacturer's instructions for proper connections and installation.

B8.3 Electrical connections must conform to National Electrical code and all local regulations. Line voltage and wire capacity must match motor rating stamped on motor nameplate.

B8.4 Electric motors - Single phase: If your mixer is supplied with a single phase motor it may be wired by the factory with a ten foot cord and an on/off switch. If no cord or switch is provided refer to the wiring diagram on the motor for correct connections. Check that the switch is in the off position before plugging the cord into a 110 volt outlet. *Check for proper rotation!* Interchange lines if necessary for proper rotation (see assembly drawing).

B8.5 Electric motors - 3 phase: Motors requiring 3 phase power must be wired according to the wiring diagrams on the motor. Rotation of the impeller must be according to the assembly drawing and data sheet. Interchange lines if necessary for proper rotation.

B8.6 Electric DC Variable Speed: Direct current variable speed electric motors using an SCR controller must be wired following the instructions supplied with the controller. Many adjustments are

often required to the SCR controller and instructions must be read carefully before applying power. See data sheet and assembly drawings for possible RPM lockout ranges. Operate only at speeds outlined on those sheets. Damage to equipment or serious injury to personnel can result, if speed limitations are not followed.

B8.7 Electric AC Variable Speed: Electric motors using an AC variable frequency controller must be wired following the instructions supplied with the controller. Many adjustments are often required to the controller and instructions must be read carefully before applying power. See data sheet and assembly drawings for possible RPM lockout ranges. Operate only at speeds outlined on those sheets. Damage to equipment or serious injury to personnel can result, if speed limitations are not followed.

B8.8 WARNING: Ground the mixer motor properly to avoid serious injury to personnel. Grounding needs to be in accordance with the National Electrical Code and consistent with local building codes.

B8.9 Other types of motors (e.g.: hydraulic) must be installed per the motor manufacturer instructions. See data sheet and assembly drawings for possible RPM lockout ranges. Operate only at speeds outlined on those sheets. Damage to equipment or serious injury to personnel can result, if speed limitations are not followed.

B8.10 Motor lubrication: Electric motor bearings are often sealed and need no relubrication. When zirc fittings are present, relubricate with a No. 2 consistency lithium soap base and petroleum compound. Relubricate every 6 months to 3 years depending on usage. Open and clean drains. Add grease until new grease is forced out drain. Remove excess grease and replace input plugs. Run motor one half hour before replacing drain plugs.

START UP & OPERATION

B9.1 WARNING: High voltage and rotating parts can cause serious or fatal injury. Lockout/Tagout power before servicing.

B9.2 Some models may be shipped "dry" (without lubricant) and must be filled with the proper lubricant before start-up. Refer to Section C for the proper type and amount of lubricant. Units shipped with oil will have the gearbox vent has been replaced with a temporary plug for shipment. **Vent must be reinstalled prior to start-up or damage may occur.** Check that the oil level is to the proper level (see Section C), and that none was lost during shipment/installation before start-up.

B9.3 Prior to applying power, test line resistance to check for possible moisture in the motor. Refer to Paragraph B1.3. Do not apply power if any resistance exceeds one to three meg-ohms.

B9.4 Rotate mixer shaft by hand to check shaft straightness and assure that the impeller is free of any obstructions in the tank.

B9.5 Extended operation of the mixer when liquid level is at or near bottom impeller is not recommended.

B9.6 The impeller rotates in the direction shown in the assembly drawing. Opposite rotation may cause overload and inefficient mixing.

B9.7 Vortexing may occur if liquid level is too close to the upper impeller. This will cause aeration of the product and excessive vibration of the equipment. When mixing products of dissimilar viscosities and/or specific gravities the lighter or less viscous material should be introduced first. Gradually add the heavier material or powders into the center of the tank while the agitator is running. Never dump large amounts of powder or solids into the mixing tank. This may create clotting or "sanding in" of impeller and cause damage to the equipment.

CAUTION: DO NOT START MIXER WITH IMPELLER BURIED IN SOLIDS OR WITH LIQUID SOLUTION SOLIDIFIED. DAMAGE WILL OCCUR.

B9.8 If impeller is buried in solids prior to starting mixer, solids must be dispersed. This may be achieved with an air hose, a recirculating pump, or a large stirring stick if necessary (depending on tank size).

B9.9 Align flexible motor coupling (**on foot mounted motors only**), to reduce wear of flexible insert of coupling. Check parallel alignment by placing a straight edge across the two coupling flanges and measuring the maximum offset at various points around the coupling (See Figure B10.1). DO NOT rotate the coupling. This dimension must be less than 0.015". Check angular alignment with a micrometer or caliper. Measure the outside of one flange to the outside of the other at intervals around the coupling (See Figure B10.2). Find the maximum and minimum dimensions. DO NOT rotate the coupling. The difference between the maximum and minimum must not exceed 0.015". Recheck both parallel and angular alignments again. Shims may be required to adjust properly.

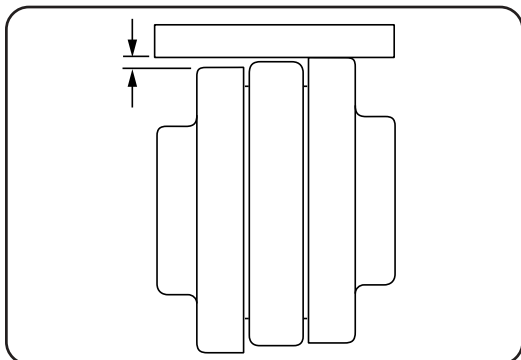

FIGURE B9.1

B9.10 Shaft seal must be lubricated/flushed during operation of mixer.

B9.11 When variable speed drives are used (AC variable frequency, air or hydraulic motors, & mechanical variable drives) run only at speeds set forth on data sheet and drawings in front of this manual. DO NOT RUN ABOVE OR BELOW SPEEDS ON DATA SHEET OR ASSEMBLY DRAWINGS. Specific data on these special drive components are located elsewhere in this manual (Section D).

B9.12 Keep motors free from oil, dust, dirt, water, and chemicals. Keep air intakes and outlets free from foreign material. Electric motors supplied, although designed for outdoor use, may be damaged due to weather. A rain hood or other protection may be necessary to prolong motor life. Consult factory for recommendations.

B9.13 Regular maintenance is the best assurance of trouble free, long life mixer operation. Inspect and relubricate at regular intervals. Frequency and thoroughness depends on operation, nature of service, and environment.

CAUTION: Before start-up, replace OSHA guards provided. Serious injury may occur if not replaced.

B9.14 In the event of a break down within the warranty period, Sharpe Mixers must be notified within 30 days if it is intended that the warranty is to cover the problem. When requesting spare/replace-ment parts anytime, have serial number and model number off mixer nameplate readily available. Do not disassemble components or otherwise modify equipment without prior authorization from Sharpe Mixers or warranty will be voided.

NOTE: Sharpe Mixers will not accept back charges for any repair work that has not been previously authorized.

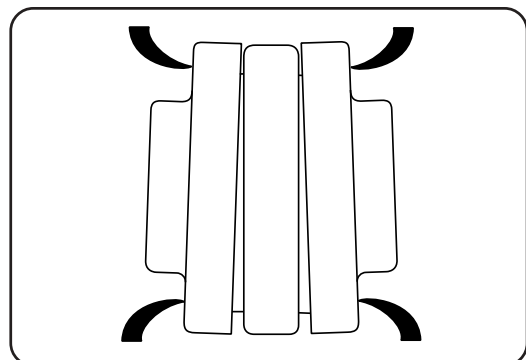

FIGURE B9.2

B9.15 Start-Up Checklist

Prior and during start-up please check that the following things have been done:

- a. Manual has been read and followed
- b. Coupling bolts torqued to specifications
- c. Hold washer tight (when applicable)
- d. Proper shaft rotation (see drawings & data sheet)
- e. Shaft alignment confirmed with hand rotation
- f. Steady bearing installed properly (when applicable)
- g. Impeller is immersed in liquid.
- h. Sufficient protection for motor (if outdoors)
- i. Impeller(s) installed correctly (see assembly drawings)
- j. Gearbox vented
- k. Mounting / Impeller bolts tight
- l. All guards in place
- m. Proper type and amount of lubricant (see Section C)
- n. Motor checked for moisture absorption
Resistance (less than 3 meg-ohms): _____
- o. Wiring correctly installed, grounded and insulated
- p. Correct voltage/amperage @ start-up:
Motor nameplate F.L.A.: _____
F.L.A. measured with ampmeter: _____
Actual line voltage measured: _____
- q. Excessive vibration of mixer support ?
- r. Speed limitations set on variable speed controller
(when applicable)
- s. Proper seal lubrication (when applicable)
- t. Proper seal run-in time allowed

INSPECTOR

DATE

TROUBLE SHOOTING GUIDE

PROBLEM	POSSIBLE CAUSE	SOLUTION
<ul style="list-style-type: none"> • Shaft will not fit into drive or coupling 	<ul style="list-style-type: none"> • Set screws extend into bore • Shaft over size (proper dia. 0.001" - 0.002" under nominal dia.) • Damaged shaft • Oversize key 	<ul style="list-style-type: none"> • Loosen set screws • Measure and consult factory • Consult factory • Grind key to fit
<ul style="list-style-type: none"> • Mixer will not start 	<ul style="list-style-type: none"> • Incorrect wiring • Loose connections • Blown fuse • Incorrect voltage • Impeller interference • Water damage to motor • Wrong size heaters in starter 	<ul style="list-style-type: none"> • Check wiring diagram and wire correctly • Check and tighten connections • Replace fuse • Wire for correct voltage • Free all debris for rotation • Service or replace motor (consult factory) • Replace heaters
<ul style="list-style-type: none"> • Mixer will not reach correct speed 	<ul style="list-style-type: none"> • Overload of motor • Loose drive coupling bolts • See "Mixer will not start" 	<ul style="list-style-type: none"> • Check amperage against nameplate data • Check coupling bolt tension (coupling and/or shaft maybe damaged if mixer has been run with slipping coupling)
<ul style="list-style-type: none"> • Motor runs hot / • Amperage overload 	<ul style="list-style-type: none"> • Low or high voltage • Product too viscous • Restricted ventilation • Frequent starting and stopping • Unbalanced voltage between phases • Incorrect rotation • Product too viscous • Incorrect rotation or upside-down impeller • Impeller too close to tank floor • Lack of/improper lubricant • Improper output speed • Build up of sediment on tank bottom • Undersized heaters 	<ul style="list-style-type: none"> • Wire for correct voltage • Check viscosity and specific gravity of product (consult factory) • Clear vents • Check with factory - a special motor may be required • Consult electrician • Change motor leads per nameplate instructions • Check viscosity and specific gravity - consult factory • Check against assembly drawings - correct if required • raise impeller • Add or change lubricant (see Section C) • Confirm speed - consult factory • Clean or irrigate sediment • Replace with correct heaters

PROBLEM	POSSIBLE CAUSE	SOLUTION
<ul style="list-style-type: none"> • Noisy 	<ul style="list-style-type: none"> • Insufficient lubricant • Foreign material in lubricant • Incorrect lubricant • Worn or faulty bearings or gears • Incorrect coupling alignment • Bent/broken guards 	<ul style="list-style-type: none"> • Fill proper amount of lubricant • Change lubricant • Change to correct lubricant <ul style="list-style-type: none"> • Check bearings/gears replace if necessary • adjust/align coupling • Straighten/replace guard
<ul style="list-style-type: none"> • Bearing failure 	<ul style="list-style-type: none"> • High temperature product • Excessive overhung load • Water damage • See all items under "Noisy" 	<ul style="list-style-type: none"> • Provide heat shield • Consult factory • Replace bearing (check all other parts)
<ul style="list-style-type: none"> • Gear failure 	<ul style="list-style-type: none"> • Excessive loading (check amps) • Lack of (or improper) lubrication • Start-stop-start loading (product burying impeller with solids) • Foreign material in lubricant 	<ul style="list-style-type: none"> • Consult factory • Fill with recommended lubricant or equivalent (see Section C) • Free impeller of any solids at start-up (pre stir with air hose or paddle) • Replace lubricant
<ul style="list-style-type: none"> • Oil leakage 	<ul style="list-style-type: none"> • Excessive lubricant • Damaged/broken gasket • Loose bolts around side plates • Seals worn or damaged • Vent not installed/clogged 	<ul style="list-style-type: none"> • Check manual for proper amount lubricant and drain excess • Replace gasket • Check and tighten bolts • Replace seals • Replace seals - install/unclog vent
<ul style="list-style-type: none"> • Shaft vibration 	<ul style="list-style-type: none"> • Impeller not immersed in liquid • Impeller too close to surface • Bent mixer shaft • Unstable mounting platform • Loose or improperly assembled coupling • Debris in coupling • Damaged gearbox bearings • Debris on impeller • Loose or bent impeller blades • Operating over maximum shaft R.P.M. 	<ul style="list-style-type: none"> • Fill tank • Fill tank or lower impeller (see Paragraph B4) • Consult factory • Reinforce platform • Assemble securely (see Para. B4) (shaft runout adjacent to coupling should be $\leq 0.005"$.) • Clean and reassemble • Check and replace if necessary • Clean impeller • Tighten or straighten (consult factory) • Reduce motor speed (variable speed only)

PROBLEM	POSSIBLE CAUSE	SOLUTION
<ul style="list-style-type: none"> • Seal leakage 	<ul style="list-style-type: none"> • Worn packing • Scored shaft • Insufficient/incorrect lubrication • Excessive heat in gland • Worn vapor seal • Split in packing rings not offset • Charred / glazed packing • Solids in seal gland • Scored shaft • Insufficient/incorrect lubrication • Excessive heat • Incorrect seal position • Excessive shaft runout 	<ul style="list-style-type: none"> • Replace packing • Replace shaft and packing check stuffing box also for possible scoring • Lubricate properly (see Paragraph B7) check for scoring - replace if necessary • Back off gland nuts (replace packing if necessary) check for scoring - replace if necessary • Replace lip seal • Remove packing, reinstall at offset (see Paragraph B7) • Improper run-in, replace packing (see Paragraph B7) • Flush properly (see Paragraph B7) • Replace shaft and seal; lubricate/flush seal • Lubricate properly (see Paragraph B7) • Lubricate properly or consult factory, a special seal may be required • See drawings in front of manual for correct position • See "Shaft vibration" above

Note: Other trouble shooting guides for special optional equipment will be located in Section D (when present).

A NOTE ON RECOMMENDED SPARE PARTS:

B10.1 Recommended spare parts are different for individual needs. The main factor affecting which parts should be kept as spares on the users shelf is downtime (allowable time period the mixer can be out of service). This list shows acceptable downtime and parts to stock as spares which, under normal circumstances, Sharpe Mixers cannot supply in less time. Note that the less downtime that is acceptable, the more spare parts that will be required to be stocked. If this equipment is critical to the plant operation, Sharpe Mixers recommends the purchase of a complete agitator to prevent extended downtime.

Allowable downtime	Recommended parts to stock for repair due to long delivery times	Typical shipment (varies)
3 weeks	-Steady bearing bushings, wear sleeves, stuffing gland throttles/bushings side entry mixer shafts, special alloy seals, and special motors.	4 weeks
2 weeks	-Above parts, plus: gearbox gear sets, motors, and mechanical seals.	4 weeks
1 week	-Above parts, plus: gearbox seals, bearings, gaskets, shims, motors, and flexible couplings.	4 weeks
3 days	-Above parts, and/or: complete gearbox, gland packing, and v-belts.	4 - 6 weeks
1 day	-Complete agitator.	4 - 12 weeks

Note: Shafts and impellers, although not normally wearing parts, may be damaged and require repair/replacement. These parts are long delivery items and should be considered if extended down time is unacceptable.

For any downtime, all wearing parts are normally recommended spares. These include: bearings, seals, gears, input couplings, and shims/gaskets. V-belts, steady bearing bushings, and wear sleeves are also recommended when present. Closed tank mixers will often require seal shaft repair/replacement if seal problems are encountered. Seal shafts are typically 4 week shipment items and should be considered a recommended spare parts item if downtime is critical.

NOTE: Replacement gearboxes should be purchased through SHARPE MIXERS. SHARPE MIXERS incorporates several modifications to the gearbox casing and internal parts to make the gearbox suitable for operation as an agitator drive. Purchasing the gearbox from other suppliers may result in incorrect selection and possible gearbox failure.

WARRANTY

For standard terms and conditions of sale including warranty, please refer to the inside front cover of this manual.

The expressed warranty implies that MIXER was purchased through SHARPE MIXERS. Warranties for MIXERS purchased through distributors must be handled through original distributor.