

OPERATION and MAINTENANCE INSTRUCTIONS for SHARPE MIXERS TOP ENTRY OPEN TANK F-SERIES MIXERS

TABLE OF CONTENTS

Section 1:	INITIAL INSPECTION, RECEIVING AND STORAGE	1
Section 2:	MOUNTING	2
Section 3:	INSTALLING THE MIXER SHAFT & IMPELLER	2
Section 4:	POSITIONING	2
Section 5:	INSTALLING THE STEADY BEARING	3
Section 6:	MOTOR CONNECTIONS	4
Section 7:	LUBRICATION	4
Section 8:	OPERATION	5
Section 9:	DIRECT DRIVE DISASSEMBLY	6
Section 10:	GEAR DRIVE DISASSEMBLY	9
Section 11:	MIXER OFFSET GUIDE	10
Section 12:	TROUBLE SHOOTING GUIDE	11
Section 13:	ACCESSORIES	12

CAUTION

Because neither manufacturer nor seller can control the application or installation of this product, their only obligation shall be to replace this part if defective and shall not be liable for any injury, loss, or damage, direct or consequential, arising from the installation of this product. User assumes all risk in using this product and is therefore cautioned in selecting the product suitable to the intended use. Refer to inside cover of this manual for Terms and Conditions.

SECTION 1 INITIAL INSPECTION, RECEIVING AND STORAGE

1.1 Immediately upon receipt of the equipment check the crating and contents for any damage that may have occurred in transit. Report any damage immediately to the carrier and to Sharpe Mixers. Check against the packing slip to be sure that all parts were received. Report missing items to the carrier and to Sharpe Mixers.

1.2 Mixer and impellers are normally packed together. The mixer shaft is packed in a separate container. Impellers are usually banded or lag-bolted to drive skid. If space allows, keep shipping containers for possible future use.

1.3 Storage: Storage is when a) mixer has been delivered to the job site and is awaiting installation, b) mixer has been installed, but regular operation is delayed, c) there are long idle periods

between operating cycles, d) plant/department operation is shut down. Store mixer in a clean, dry location, with circulating air, free from wide variations in temperature. Electric motors are easily damaged by moisture. Store the entire unit off the floor, covered with plastic, and use desiccants to reduce moisture buildup. Do not seal the plastic cover as this traps moisture. If the motor shows signs of moisture absorption before start-up, dry the motor out by applying 10% voltage on two leads (if in doubt, measure resistance in windings). This will give approximately 50% rated current. There are also sprays available to help dry out motors. Relubricate motor before start-up when in storage six months or more. When gear drive models have been in storage for more than a year, the condition of the gear lubricant should be inspected (see Paragraph 7.1).

SECTION 2 MOUNTING

2.1 Both the plate mount and angle mount use four (4) 3/8" bolts on a nine inch (9") square spacing (see page 8) to mount the mixer to your mixer support above the tank. Double nutting is recommended to prevent bolts from loosening by equipment vibration.

2.2 Mounting structure must be stable and strong enough to allow the vibration mounts to flex under mixer load which minimizes stress on longer shafts. If mounting to an unstable support, mixer loads may cause damage to the equipment, tank, or other hazards.

SECTION 3 INSTALLING THE MIXER SHAFT & IMPELLER

(refer to pages 7 or 8)

WARNING: Always lockout power before installing or servicing the mixer shaft and impeller.

3.1 The mixer shaft will have one end (marked: motor end) ground to fit the drive bearing and coupling. Slide the impeller(s) onto the opposite end with the concave side of the blades facing AWAY from motor end of shaft. A single impeller is best mounted at the end of the shaft or 1-2 prop diameters above tank bottom. The upper impeller (if supplied) is normally mounted a minimum of 2 impeller diameters below the liquid surface. Tighten the set screws securely. High horsepower units will have "divots" into which the set screws must be tightened.

3.2 Remove the service window (512) from the mixer spool so the bearing and coupling are visible (see page 7 or 8). Rotate the coupling until the two clamping bolts (651) are accessible. Install the mixer shaft (with the end marked motor end) up through the lip seal, bearing, and into the drive coupling (650). Using the 3/16" hex wrench supplied, **TIGHTEN THE TWO BOLTS IN THE COUPLING (651)**, gripping the mixer shaft in position. Tighten **SECURELY** as these bolts transmit the mixer torque. **TIGHTEN THE TWO BEARING SET SCREWS (310)**, using the 1/8" hex wrench provided.

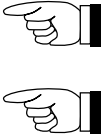

SECTION 4 POSITIONING

WARNING: Always lockout power before positioning or repositioning the mixer.

4.1 The following drawings are for reference only. If there is any question concerning the proper position of your F-series mixer, please contact your Sharpe Mixers representative or the factory as your specific application may be different than recommendations shown.

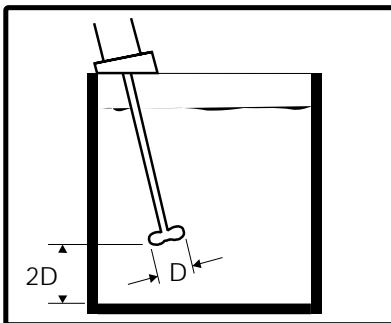

4.2 If tank diameter is approximately equal to liquid depth, use 1 prop, placed at least 2 prop diameters from the bottom of the tank.

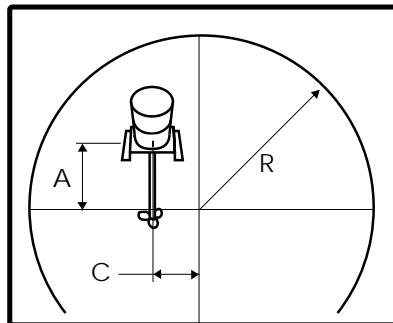

4.3 See drawing A2787 in section 11 for angular offset mounting dimensions. Consult factory for special applications, including square/rectangular tanks.

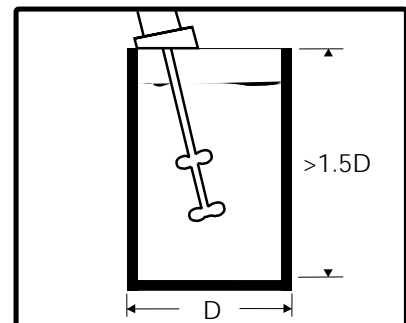

4.4 If tank height is greater than 1.5x the diameter, use 2 props. Position lower prop at least 2 prop diameters from bottom. Place upper prop halfway between bottom and top of liquid level.

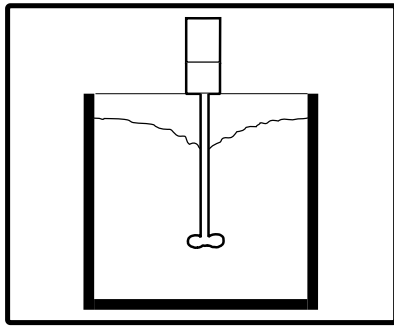

4.5 For drawing down light powders, position mixer in center of tank to create a vortex. A vortex may not be recommended for some products. Depth of prop will vary vortex.

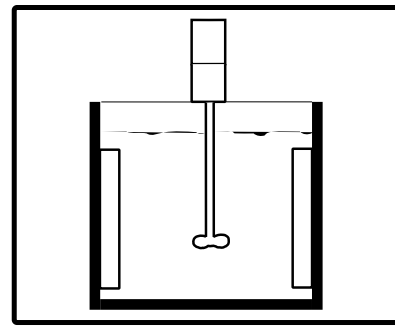

4.6 Baffles may be used to prevent vortexing when mixer is mounted on center. Baffling may not be required with more viscous products or square/rectangular tanks.

SECTION 5 INSTALLING THE STEADY BEARING *(optional equipment)*

WARNING: Always lockout power before installing or servicing the steady bearing. Never run mixer without the steady bearing installed.

5.1 This section is for mixers which include an optional steady bearing to accommodate longer than standard mixer shafts. A steady bearing must be installed only after the drive assembly and lower mixer shaft have been assembled and firmly bolted in place. DO NOT predetermine the bearing location from tank and mixer outline dimension drawings. The vertical center line of the steady bearing must coincide with the shaft's natural axis of rotation to minimize bearing preload (see Figure B5.1). This axis may not necessarily be at the center of the tank. The mixer shaft must be hand rotated (using input shaft coupling or motor fan) with a fixture attached to the shaft to mark a line on the tank bottom. The center

of this inscribed area will be the location for the center of the steady bearing.

5.2 The steady bearing must be securely installed with its vertical centerline aligned with the axis of rotation of the shaft, as established in Paragraph 5.1. The amount of lateral movement required to bring the shaft into proper alignment with the final steady bearing location will vary depending upon the shaft length and diameter.

5.3 The shaft/wear sleeve must be fully engaged with the bearing.

5.4 The steady bearing and wear sleeve are wearing parts and should be checked periodically. Sharpe Mixers recommends that a spare bearing and wear sleeve be kept in stock at all times.

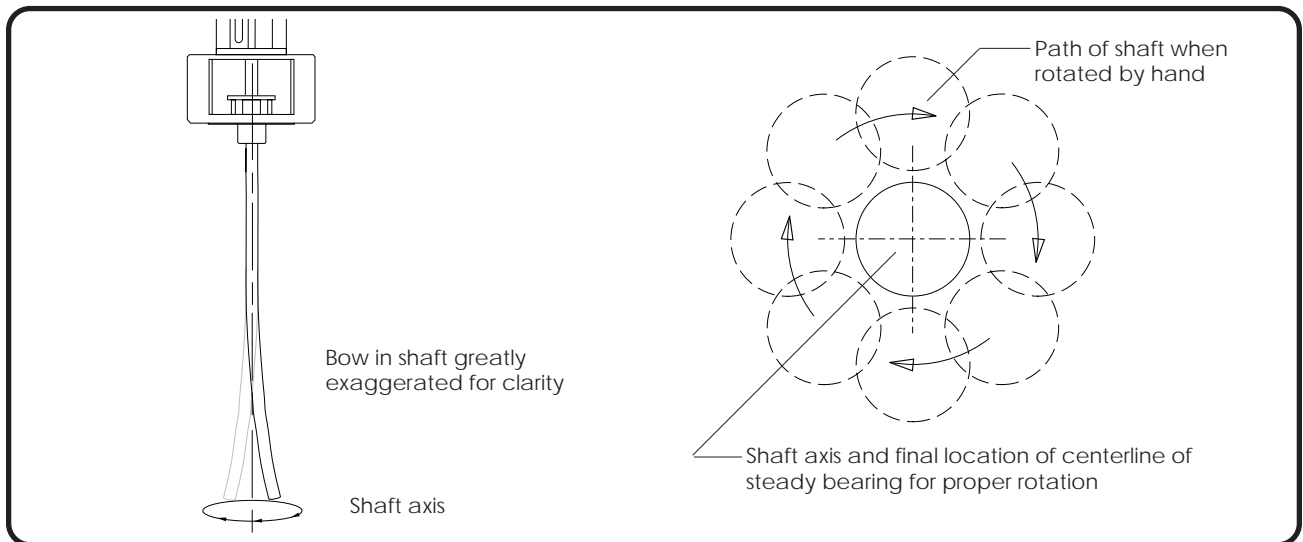

FIGURE 5.1

SECTION 6 MOTOR CONNECTIONS

WARNING: High voltage and rotating parts can cause serious or fatal injury. Electric machinery can be hazardous. Installation, operation, and maintenance of electric machinery should be performed by qualified personnel. Familiarity with NEMA safety standards, National Electrical Code and local building codes are required.

6.1 Wiring: Starting and overload control devices must be matched to motor rating. Follow control manufacturer's instructions for proper connections and installation.

6.2 Electrical connections must conform to National Electrical code and all local regulations. Line voltage and wire capacity must match motor rating stamped on motor nameplate.

WARNING: Ground the mixer motor properly to avoid serious injury to personnel. Grounding needs to be in accordance with the National Electrical Code and consistent with local building codes.

6.3 Electric motors - Single phase: If your mixer is supplied with a single phase motor it may be wired by the factory with a ten foot cord and an on/off switch. If no cord or switch is provided refer to the wiring diagram on the motor for correct connections. Check that the switch is in the off position before plugging the cord into a 110 volt outlet. *Check for proper rotation!* Interchange lines if necessary for proper rotation (see assembly drawing).

6.4 Electric motors - 3 phase: Motors requiring 3 phase power must be wired according to the wiring diagrams on the motor. Rotation of the impeller must be according to the assembly drawing and data sheet. Interchange lines if necessary for proper rotation.

6.5 Electric Variable Speed: Electric motors using an SCR or variable frequency controller must be wired following the instructions supplied with the controller. Many adjustments are often required to the controller and instructions must be read carefully before applying power. Adjust the controller to limit the maximum speed to the motor nameplate R.P.M. (or refer to the motor speed in the data sheet at the front of this manual).

6.6 Air motors: Air driven mixers must always have a filter, lubricator and moisture trap installed in the air line ahead of the motor to prevent damage. Use the same size or next pipe size larger than intake port of motor. A regulator may be used to govern the mixer speed. Install the air line in the proper port to provide proper rotation. These accessories are available from Sharpe Mixers.

WARNING: Damage to equipment or serious injury to personnel can result if speed limitations are not followed.

SECTION 7 LUBRICATION

7.1 Your mixer has been lubricated at the factory with the proper type and amount of lubrication for mixer service (gear drive units only). This lubricant needn't be changed under normal conditions for a period of 3 years. Under extreme conditions it is recommended that the lubricant in the gear box be changed more frequently . Remove motor to

repack gearbox. Refer to the chart below for the lubricant recommended for temperatures in your area. When changing to a different lubricant, clean gearbox with mineral spirits before repacking.

SERVICE	LUBRICANT	CHEVRON EQUIVALENT
32°F (0°C) and up	Oil based EP semi fluid grease	BLACK PEARL NLGI 1 (standard from factory)
Down to -20°F (-29°C) and up to 300°F (149°C)	Synthetic EP-2	ULTI-PLEX Synthetic grease EP (Grade 1)
Food grade	Food grade EP-2	Chevron FM grease EP2

7.2 **Electric motor bearings** are usually sealed and need no relubrication. If zirc fittings are present, lubricate with a No. 2 consistency lithium soap base and petroleum compound. Relubricate every 6 months to 3 years depending on usage. Open and clean drains. Add grease until new grease is forced out drain. Remove excess grease and replace input plugs. Run motor one half hour before replacing

drain plugs. Mixer shaft bearings are sealed and need no relubrication.

7.3 **Air motor lubrication:** Lubricator needs to be adjusted to feed one drop of oil for every 50 - 75 CFM of air through the motor. Use a detergent SAE #10 automotive engine oil.

SECTION 8 OPERATION

WARNING: High voltage and rotating parts can cause serious or fatal injury. Lockout/Tagout power before servicing.

8.1 Rotate mixer shaft by hand to check shaft straightness to assure that the impeller is free of any obstructions in the tank.

8.2 **Always operate mixer with the lower impeller immersed** in the liquid by at least one prop diameter. Never operate mixer if fluid level falls near the lower impeller.

8.3 Unless otherwise stated in the data sheet, the propeller rotates clockwise when viewed from above. Opposite rotation may cause overload and inefficient mixing.

8.4 Vortexing may occur if liquid level is too close to the upper impeller. This will cause aeration of the product and excessive vibration of the equipment. When mixing products of dissimilar viscosities and/or specific gravities the lighter or less viscous material should be introduced first. Gradually add the heavier material or powders into the center of the tank while the agitator is running. Never dump large amounts of powder or solids into the mixing tank. This may create clotting or "sanding in" of impeller and cause damage to the equipment.

8.5 If impeller is buried in solids prior to starting mixer, solids must be dispersed. This may be achieved with an air hose, a recirculating pump, or a large stirring stick if necessary.

8.6 Shaft vibration is normal with an F-series

mixer. The rubber vibration mounts on the mixer mount are designed to allow shaft vibration without damaging the mixer drive. Excessive vibration may be caused by a shaft or impeller which has been bent, possibly in shipment. Consult factory for recommendations.

8.7 Keep motors free from oil, dust, dirt, water, and chemicals. Keep air intakes and outlets free from foreign material. Electric motors supplied, although designed for outdoor use, may be damaged due to weather. A rain hood or other protection may be necessary to prolong motor life. Consult factory for recommendations.

8.8 **CAUTION:** Do not drive air motors above 1750 R.P.M.. See Figure 8.1 and 8.2 for proper air consumption and pressures.

8.9 Regular maintenance is the best assurance of trouble free, long life mixer operation. Inspect and relubricate at regular intervals. Frequency and thoroughness depends on operation, nature of service, and environment.

8.10 In the event of a break down within the warranty period, Sharpe Mixers must be notified within 15 days if it is intended that the warranty is to cover the problem. When requesting spare/replace-ment parts anytime, have serial number and model number off mixer nameplate readily available. Do not disassemble components or otherwise modify equipment without prior authorization from Sharpe Mixers or warranty will be voided. Sharpe Mixers will not accept back charges for any repair work that has not been previously authorized.

4AM AIR MOTOR @ 1750 MAXIMUM R.P.M.					
H.P.	0.25	0.5	0.75	1.0	1.2
C.F.M.	14	22	30	39	48
P.S.I.	20	40	60	80	100

FIGURE 8.1

6AM AIR MOTOR @ 1750 MAXIMUM R.P.M.					
H.P.	0.5	0.5	1.0	2.2	2.6
C.F.M.	23	39	53	68	82
P.S.I.	20	40	60	80	100

FIGURE 8.2

8.11 **Start-Up Checklist**

Prior and during start-up please check that the following things have been done:

- a. Manual has been read and followed
- b. Coupling bolts tight (3/16" hex "tee" wrench)
- c. Bearing setscrews tight (1/8" hex allen wrench)
- d. Impeller is immersed in liquid
- e. Sufficient protection for motor (if outdoors)
- f. Impeller(s) installed correctly (see Paragraph 3.1)
- g. Impellers spaced correctly (if two or more)
for maximum and minimum liquid level
(see Paragraph 3.1)
- h. Correct heaters installed for overload protection
- i. All mounting bolts and impeller bolts tight
- j. Proper type and amount of lubricant
(when serviced; see Paragraph 7.1)
- k. Wiring correctly installed, grounded and insulated
- l. Proper shaft rotation (clockwise looking down)
- m. Steady bearing installed properly (if supplied)
- n. Correct voltage/amperage upon starting
(check against motor nameplate data)
Record: _____ Volts _____ amps
- o. Excessive noise after start-up ?
Record: _____ db _____ @3'
- p. Excessive vibration of mixer support ?

INSPECTOR

DATE

**SECTION 9
DIRECT DRIVE DISASSEMBLY**

9.1 Disconnect power from the mixer.

WARNING: High voltage and rotating parts can cause serious or fatal injury. Lockout/Tagout power before servicing.

9.2 Remove the service window (512). Loosen the two bearing setscrews (310) and the two lower coupling bolts (651) and remove the mixer shaft. Remove the four 3/8" bolts mounting the motor to the spool and then the two may be separated.

9.2 BEARING AND SEAL REMOVAL: Place the mixer spool in a bench press with the motor mounting face down. Use a 1 - 1/2" diameter arbor in the press

on top of the lip seal (360) and press the lip seal and the bearing (301) down and out of the spool.

9.3 Reinstall the bearing from the inside of the spool, using a LOCTITE® sealant (609 or better) to hold the bearing in place. The lip seal (360) should be installed from the outside of the spool into position as shown in the drawing.

9.5 To reassemble, reverse procedure, being sure the shaft has full engagement in the split coupling (650) and all fasteners are tight.

GEAR DRIVE PARTS LIST

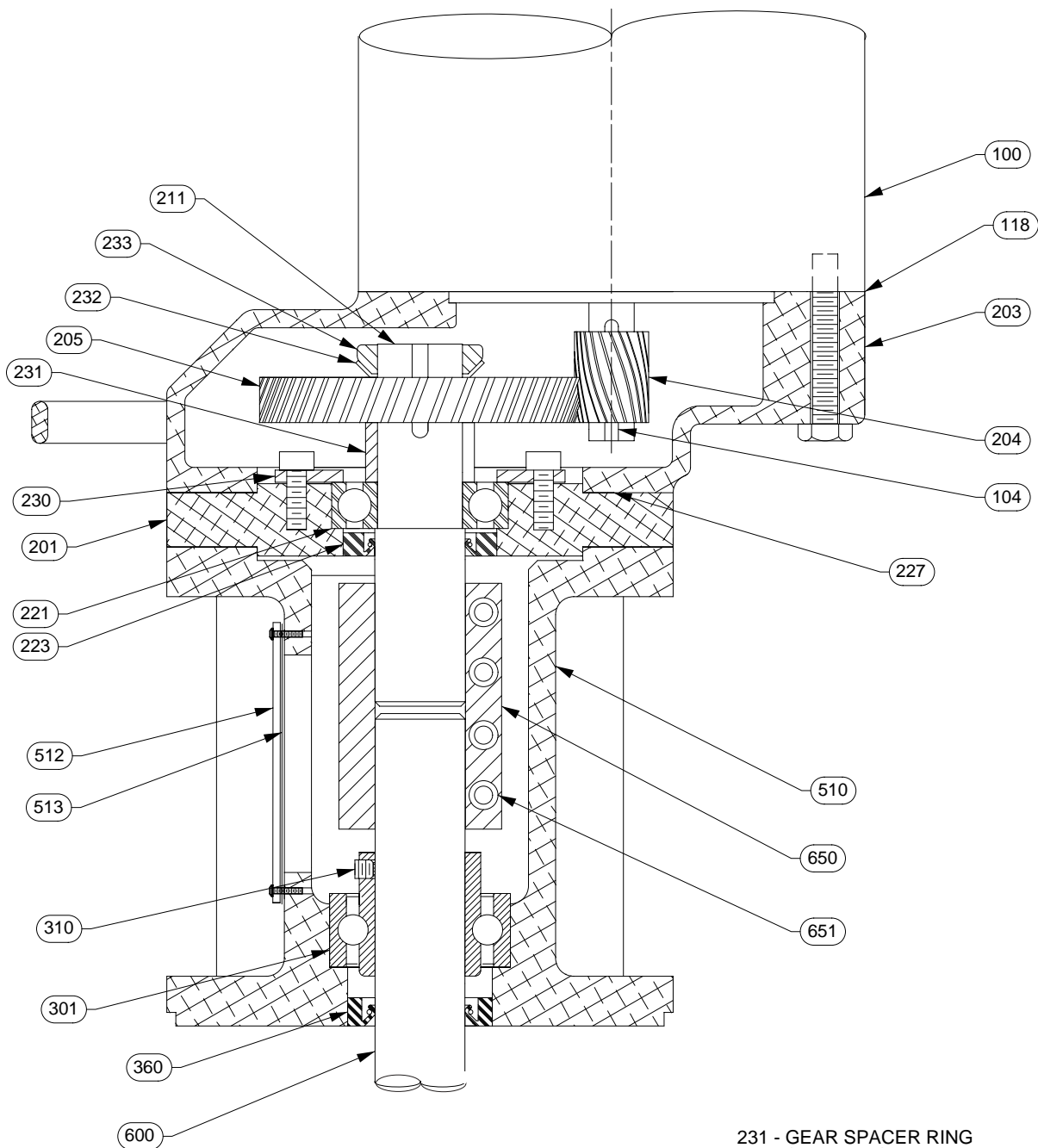

- ▽ 100 - MOTOR
- ▽ 104 - PINION GEAR KEY
- ▽ 118 - C-FACE GASKET
- ▽ 201 - BEARING PLATE
- ▽ 203 - GEAR HOUSING
- ▽ 204 - PINION GEAR
- ▽ 205 - HELICAL GEAR
- ▽ 211 - GEAR SHAFT
- ▽ 221 - GEARBOX BEARING
- ▽ 223 - GEARBOX LIP SEAL
- ▽ 227 - GEARBOX GASKET
- ▽ 230 - BEARING RETAINER

- ▽ 231 - GEAR SPACER RING
- ▽ 232 - STAR WASHER
- ▽ 233 - GEAR NUT
- ▽ 301 - SHAFT BEARING*
- ▽ 310 - (2) S. S. BRASS TIPPED SET SCREWS
- ▽ 360 - SHAFT LIP SEAL*
- ▽ 510 - BEARING SPOOL
- ▽ 512 - SERVICE WINDOW
- ▽ 513 - SERVICE WINDOW GASKET
- ▽ 600 - MIXER SHAFT*
- ▽ 650 - COUPLING*
- ▽ 651 - (4) SPLIT COUPLING BOLTS

* NOTE - WHEN ORDERING PARTS, GIVE SERIAL NO. AND SHAFT SIZE.
 ▽ DENOTES RECOMMENDED SPARE PART

SECTION 10 GEAR DRIVE DISASSEMBLY

10.1 Disconnect power from the mixer.

WARNING: High voltage and rotating parts can cause serious or fatal injury. Lockout/Tagout power before servicing.

10.2 Remove the service window (512). Loosen the two bearing set screws (310) and the two lower coupling bolts (651) and remove the mixer shaft.

10.3 Remove the three motor bolts and the motor may be lifted off the gear head assembly. Remove the four (4) 3/8" gear head assembly bolts and lift off the gearbox housing (253). The bearing plate (201) may now be removed with the gear, gear shaft and coupling assembled. Clean the assembly of grease and rinse with mineral spirits. Handling the gear shaft subassembly is best accomplished using a piece of round bar the same diameter as the mixer shaft. Clamp the round bar in a bench vise and tighten the drive coupling (650) onto the round bar. If a round bar is not available clamp the coupling in the vise using two pieces of wood so as not to damage the coupling. To remove the gear nut (233) first bend down the locking tab on the star washer from the slot in the gear nut. Using a spanner wrench, loosen the gear nut from the shaft. Remove the gear nut and the star washer. The slow speed gear (205) may be removed using a gear puller if it is too tight to remove by hand. Gear teeth are hardened and are easily chipped. Use care when handling. Loosen the upper two coupling bolts and remove the gear shaft/bearing plate assembly from the coupling. Place the subassembly in a press with the threaded end of the shaft pointing up. Remove the spacer ring (231) from the gear shaft. Press the gear shaft (211) down, out of the bearing plate. Remove the four 1/4" cap screws and the bearing retaining ring (230). Turn the bearing plate upside down so that the lip seal (223) is on top. Using a 2"

diameter arbor press the lip seal and the bearing out of the bearing plate. See Paragraph 9.2 for removal of bearing and lip seal in the spool.

10.4 To remove pinion gear (204) from the motor shaft, first clean the pinion gear and motor shaft of grease. Support the motor shaft with a soft block to prevent damage when removing the pinion gear. The pinion gear may be removed from the motor shaft using a gear puller. Use care to not chip the teeth of the hardened gear. Apply heat to break the adhesion of the Loctite®.

10.5 To reassemble a new gear on an existing motor, clean all parts and trial fit the pinion gear on the shaft. Never pound the pinion gear into place. Assemble gear and key flush with the end of the motor shaft using Loctite® # RC-680 compound. Remove any excess Loctite® from the gear, especially from the gear teeth. If replacing both the motor and pinion gear, Sharpe Mixers will normally supply the motor with the pinion gear installed. Pack the gearbox full with the appropriate lubricant (see Section 7).

Always reference mixer serial number when making a parts inquiry or placing an order. This serial number is located on the Sharpe Mixer nameplate and on the front cover of the service manual.

MARINE PROPELLERS ARE STANDARD
ON DIRECT DRIVE F-SERIES MIXERS



HYFLO II ENERGY EFFICIENT IMPELLERS ARE STANDARD
ON GEAR DRIVE F-SERIES MIXERS

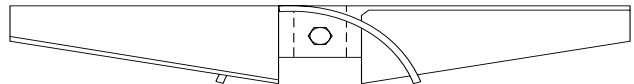

SECTION 12
TROUBLE SHOOTING GUIDE

PROBLEM	POSSIBLE CAUSE	SOLUTION
<ul style="list-style-type: none"> •Shaft will not fit into drive 	<ul style="list-style-type: none"> •Wrong end of shaft (only one end fits) •(2) bearing set screws (310) extend into bearing bore •(2) coupling bolts (651) too tight •Shaft over size (proper dia. 0.001" - 0.002" under nominal dia.) •Wrong size shaft (600), coupling (650), or bearing (301) •Damaged shaft (600), coupling (650), or bearing (301) 	<ul style="list-style-type: none"> •Install end marked "motor end" •Loosen set screws •Loosen bolts •Measure and consult factory •Consult factory •Consult factory
<ul style="list-style-type: none"> •Mixer will not start 	<ul style="list-style-type: none"> •Incorrect wiring •Loose connections •Blown fuse •Incorrect voltage •Mechanical jamming •Water damage to motor •Wrong size heaters in starter 	<ul style="list-style-type: none"> •Check wiring diagram and wire correctly •Check and tighten connections •Replace fuse •Wire for correct voltage •Free all debris for rotation •Service or replace motor •Replace heaters
<ul style="list-style-type: none"> •Mixer will not reach correct speed 	<ul style="list-style-type: none"> •Overload of motor •Loose drive coupling bolts (651) •Air motor vanes/ports dirty •Insufficient pressure for air motor •See "Mixer will not start" 	<ul style="list-style-type: none"> •Check amperage against nameplate data •Check coupling bolt tension (coupling and/or shaft maybe damaged if mixer has been run with slipping coupling) •Flush air motor with non-combustible solvent - relubricate •Increase air line, compressor size, decrease air compressor distance from air motor
<ul style="list-style-type: none"> •Motor runs hot 	<ul style="list-style-type: none"> •Low or high voltage •Amperage overload •Product too viscous •Restricted ventilation •Frequent starting and stopping •Unbalanced voltage between phases •Incorrect rotation •Air motor not lubricated properly •Impeller upside-down •Exceeding maximum speed 	<ul style="list-style-type: none"> •Wire for correct voltage •Contact factory •Check viscosity and specific gravity of product (consult factory) •Clear vents •Check with factory - a special motor may be required •Consult electrician •Change motor leads per nameplate instructions •Lubricate (see Paragraph 7.1) •Reinstall in correct position •Adjust variable speed drive to limit R.P.M.

PROBLEM	POSSIBLE CAUSE	SOLUTION
• Noisy	<ul style="list-style-type: none"> • Loose drive coupling bolts (651) or bearing set screws (310) • Insufficient lubricant • Foreign material in lubricant • Incorrect lubricant • Worn or faulty bearings / gears • Dry lip seal (360) in spool 	<ul style="list-style-type: none"> • Check and tighten coupling bolts and set screws • Fill proper amount of lubricant • Change lubricant • Change to correct lubricant • Check bearings/gears replace if necessary • Apply lubricant to lip seal
• Bearing failure	<ul style="list-style-type: none"> • High temperature product • Excessive overhung load • Water damage • See all items under "Noisy" 	<ul style="list-style-type: none"> • Provide heat shield • Consult factory • Replace bearing (check all other parts)
• Gear failure	<ul style="list-style-type: none"> • Excessive loading (check amps) • Lack of (or improper) lubrication • Start-stop-start loading (product burying impeller with solids) • Foreign material in lubricant 	<ul style="list-style-type: none"> • Consult factory • Fill with recommended lubricant or equivalent (see Paragraph 7.1) • Free impeller of any solids at start-up (pre stir with air hose or paddle) • Replace lubricant
• Oil leakage	<ul style="list-style-type: none"> • Excessive lubricant • Damaged/broken gasket • Loose bolts around side plates • Seals worn or damaged 	<ul style="list-style-type: none"> • Check manual for proper amount lubricant and drain excess • Replace gasket • Check and tighten bolts • Replace seals
• Shaft vibration	<ul style="list-style-type: none"> • Impeller not immersed in liquid • Impeller too close to surface • Bent mixer shaft • Unstable mounting platform • Operating at critical speed 	<ul style="list-style-type: none"> • Fill tank • Fill tank or lower impeller (see Paragraph 3.1) • Consult factory • Reinforce platform • Consult factory

SECTION 13 ACCESSORIES

AIR FILTER, REGULATOR, LUBRICATOR



An air filter, regulator, and lubricator must be used with air drive portable mixers. If your system already has a filter, regulator, and lubricator, a needle valve is used for motor speed adjustment. These are available from Sharpe Mixers



A "Mixer Fixer Kit" is available for rebuilding your Sharpe portable mixer. This kit includes all bearings, seals, (gears, when applicable) and other recommended spare parts as shown on pages 7 and 8 of this manual (motor optional). Call Sharpe - Mixers for current prices.