

# SHARPE ELECTRIC-LIFT MIXER STANDS

*Stainless Steel  
Lift Stands for  
Portable Mixers*



- SS316 construction
- Available in 36", 48" and 60" sizes
- Heavy-Duty construction for sturdy operation and long trouble-free life
- 1/2 hp SS Wash-Down motor standard
- Oversize SS worm gear drive standard
- Includes pendant switch for raising/lowering
- Available with locking tank positioning clamp and strap
- Shown with locking SS casters. Also available with leveling glides, or may be bolted directly to floor

**SHARPE  
MIXERS**

(800) 237-8815 [www.sharpemixers.com](http://www.sharpemixers.com)

## OPTIONS

|  |  |
|--|--|
| STAND MATERIAL: <input type="checkbox"/> M/S<br><input type="checkbox"/> SS            | BASE: <input type="checkbox"/> STD. X-LEGS<br><input type="checkbox"/> SQUARE BASE<br><input type="checkbox"/> OTHER: _____  |
| MIXER MOUNTING: <input type="checkbox"/> CUP PLATE<br><input type="checkbox"/> C-CLAMP | BASE MOUNTING: <input type="checkbox"/> STD. LEVELING FEET<br><input type="checkbox"/> CASTERS<br><input type="checkbox"/> NONE<br><input type="checkbox"/> OTHER: _____ |
| TANK ARM: <input type="checkbox"/> YES<br><input type="checkbox"/> NO                  |  |

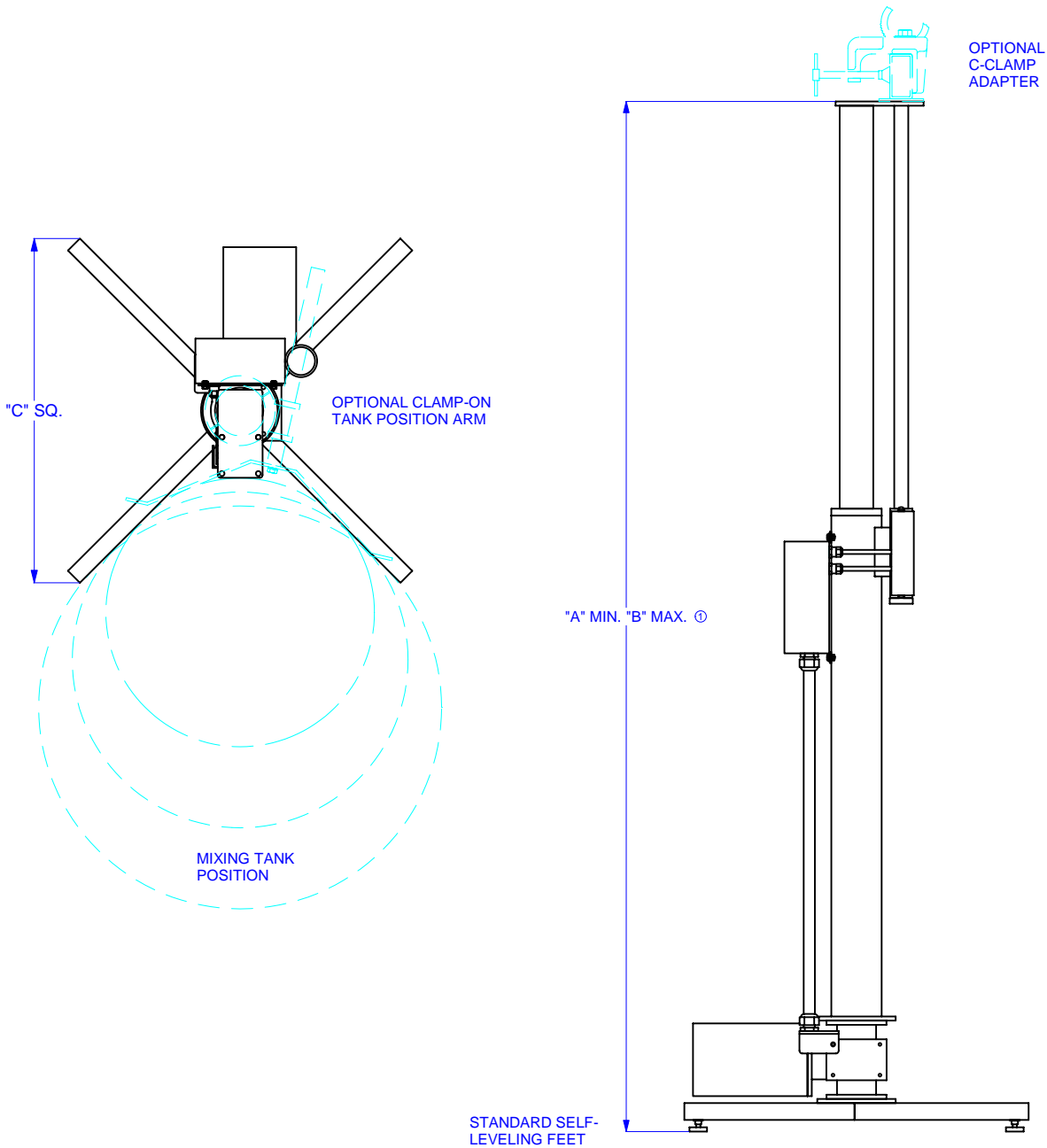

BOLTED BASE DESIGNED FOR EASY DISASSEMBLY, STORAGE, AND SHIPMENT

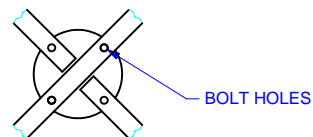

|          | ELS-36 | ELS-48 | ELS-60 |
|----------|--------|--------|--------|
| "A"      | 56"    | 68"    | 80"    |
| "B"      | 92"    | 116"   | 140"   |
| "C"      | 31"    | 36"    | 57"    |
| WT, LBS* | 180    | 200    | 220    |
| STROKE   | 36"    | 48"    | 60"    |

\*APPROXIMATE AND DOES NOT INCLUDE WEIGHT OF MIXER

Ⓞ ADD 3" TO THESE DIMENSIONS WHEN CASTERS ARE SUPPLIED

## MIXER STAND LAYOUT

DWG NO.: A12969

drawn by: MS Date: 1/20/09 revision: 0